

# MF 8, 12, 16, 24

PROFESSIONAL POWER AMPLIFIERS  
MF SERIES

## OWNERS MANUAL

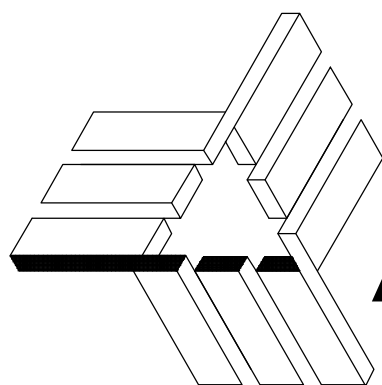

# ALTAiR

**EQUIPOS EUROPEOS ELECTRÓNICOS, S.A.L.**  
AVDA. DE LA INDUSTRIA, 50. 28760 TRES CANTOS (MADRID)



91-8043265



91-8044358



altair@altairaudio.com.

[www.altairaudio.com](http://www.altairaudio.com)

# CONTENTS

<b>1. INTRODUCTION</b>	3
<b>2. SWITCHES, INDICATORS, ATTENUATORS AND CONNECTORS.</b>	5
MF8 AND MF12 FRONT PANEL	5
MF16 AND MF24 FRONT PANEL	5
MF8 AND MF12 REAR PANEL	6
MF16 AND MF24 REAR PANEL	6
<b>3. WORKING PRECAUTIONS</b>	7
<b>4. INSTALLATION</b>	7
UNPACKING	7
MOUNTING	7
CHANGING THE FUSE	8
CONNECTING TO THE MAINS	8
INPUT CONNECTION	9
UNBALANCED INPUT	10
BALANCED INPUT	10
OUTPUT POWER CONNECTION. MODES OF OPERATION	11
STEREO MODE OPERATION	12
MONO MODE OPERATION	12
BRIDGE MODE OPERATION	13
EARTH LINK	14
<b>5. OPERATION</b>	14
POWER UP	14
INPUT ATTENUATORS	15
BRIDGE MODE INDICATOR	15
CLIP INDICATORS (INPUT SIGNAL OVERLOAD)	15
SIGNAL INDICATORS	15
ERROR INDICATORS	16
THERMAL INDICATORS	16
ON/STBY INDICATORS	16
POWER SWITCH	17
FAN	17
LOAD IMPEDANCES	17
MAINTENANCE	18
AMPLIFIER CONDITIONS	19
<b>6. SPECIAL OPERATIONS</b>	21
CHANGING XLR INPUT CONNECTORS POLARITY	22
INPUT ATTENUATOR CONFIGURATION IN MODE MONO (MF16 AND MF24 ONLY)	23
LIMITER ON/OFF	23
INPUT SENSIBILITY/GAIN ADJUST	24
<b>7. DISTRIBUTED SYSTEMS APPLICATION (PUBLIC ADDRESS)</b>	25
<b>8. TECHNICAL SPECIFICATIONS</b>	26
<b>9. GRAPHS</b>	27
<b>10. WARRANTY</b>	28

## 1. INTRODUCTION

Congratulations on your purchase of the ALTAiR power amplifier MF series. Our dilated experience in the design and manufacture of great power amplifiers culminate with the presentation of this new generation of amplifiers MF series.

There is a lot the characteristics that make of the ALTAiR power amplifiers MF series, one of the most highlighted of the audio professional market, here enumerated some:

### **Flexibility in the input connections**

They had a input system that is configured by means of a panel that integrates two XLR connectors male-female per channel (a female XLR + Jack in the models MF8 MF12 over the own chassis) and a switch of work mode. By means of this system, one could change the polarity and the sensibility of the power amplifier in order to allow its integration in any sound system. This segregation of the elements corresponding to the input signal opens the possibility of incorporating remote control circuits easily, crossovers, as well as simplify the maintenance works .

### **Multiple protection**

As global protection, incorporates turn on switches with thermal breaker (models MF16 MF24). These switches, located at the front panel substitute to the old fuses with the rising advantages: its holds their own curve indefinitely, it that is unchanged with the temperature, show the shooting by means of the lever state and avoids locating and substitute the typical blended fuse.

Has improved the circuits of DC output protection with the incorporation of CROW-BAR circuits or solid state relays. The conventional relays incorporate contacts associated with electromechanical elements that with the time are subject to failures. This is no longer with the solid state device. Guiding directly the power transistors output to the loudspeakers binding post has improved several qualities of the signal quality, the damping factor and the global reliability.

Equally, the conventional thermal switches (based on contacts) has been substituted of the power modules by solid state sensors whose information completes the double condition of speed fan control and discharge the thermal protection.

The power supply transformer is protected also in front of excessive heating, disconnecting both inputs until their normal temperature of operation is reached.

All the protection situations are displayed in the power amplifier front panel.

### **Clipping circuit limiter**

Since most of the damage caused to loudspeakers, and even in the power amplifiers, is normally the result of the permanence of the power unit during long periods of time in clipping, it is necessary to be able to have limiter mechanisms that assure their reliable operation.



For this purpose, all the MF series power amplifiers has a “soft-clipping” circuit that acts on the output power by comparing the input and output signals. Once it detects a distortion or other noticeable cut, it stabilizes the integrity of the output signal thereby avoiding overloading and saturation levels that might damage the system.

### **Monoblock chassis**

The chassis is of construction of a single piece: the efforts of the different subsets of the equipment fall on an only piece of laminate steel of great thickness and reinforced toward their union with the wings. Avoids the breaks and the “loss of screws” because of the own vibrations give them teams in continuous tour.

### **Under control**

The conception of the new loudspeakers, especially the uses for low frequencies is based on that the amplifiers that govern them behave as ideal tension amplifiers, is say with zero output impedance. The MF series approaches to this value nearly zero presenting a damping factor better than 700 what redounds in a perfect control of the position of the reels along all their excursion.

Naturally, you want to use your power amplifier, but before beginning is important that you read this manual. This manual will help you to install and use your new power amplifier. It is very important that you read it carefully, mainly the paragraphs marked as NOTE, PRECAUTION and DANGER, for your security.

Save the original packing, you could use if you need to transport the power amplifier.  
**NEVER SHIP THE POWER AMPLIFIER WITHOUT IT'S ORIGINAL PACKING.**

## 2. SWITCHES, INDICATORS, ATTENUATORS AND CONNECTORS.

These are the switches, indicators, attenuators and connectors that you could find in your power amplifier. The description and explanation of each one of them, you will find it in the corresponding section.

### MF8 AND MF12 FRONT PANEL

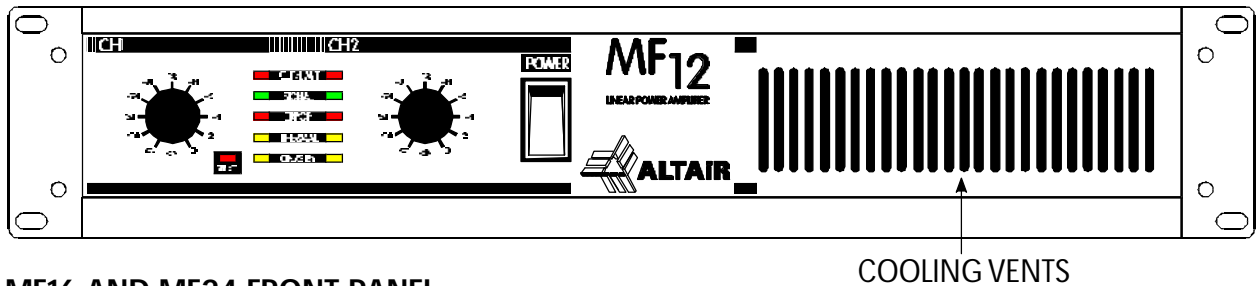

### MF16 AND MF24 FRONT PANEL

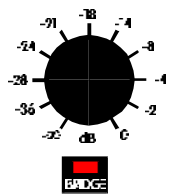
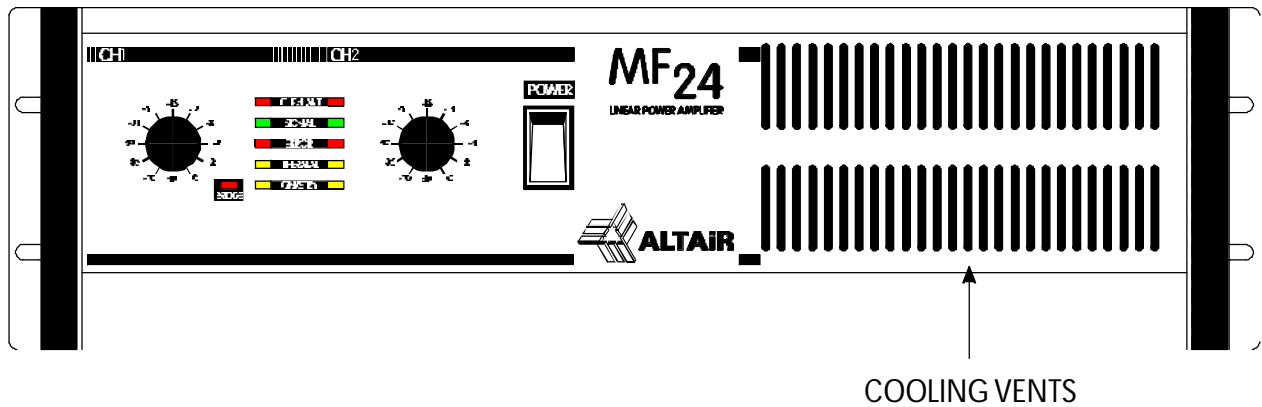

INPUT ATTENUATOR.



BRIDGE MODE INDICATOR.

INPUT SIGNAL OVERLOAD INDICATOR.



SIGNAL INDICATOR.



ERROR INDICATOR (D.C. OR TURN ON).



THERMAL PROTECTION INDICATOR.



TURN ON / STAND BY INDICATOR.

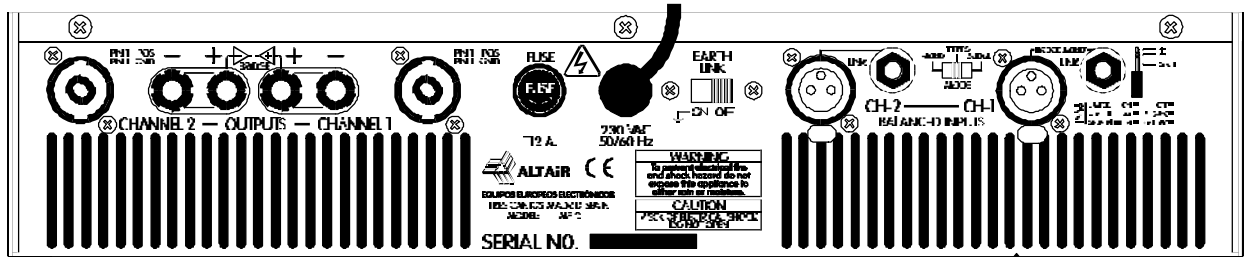

POWER SWITCH.

**MF8 AND MF12 REAR PANEL**

COOLING VENTS

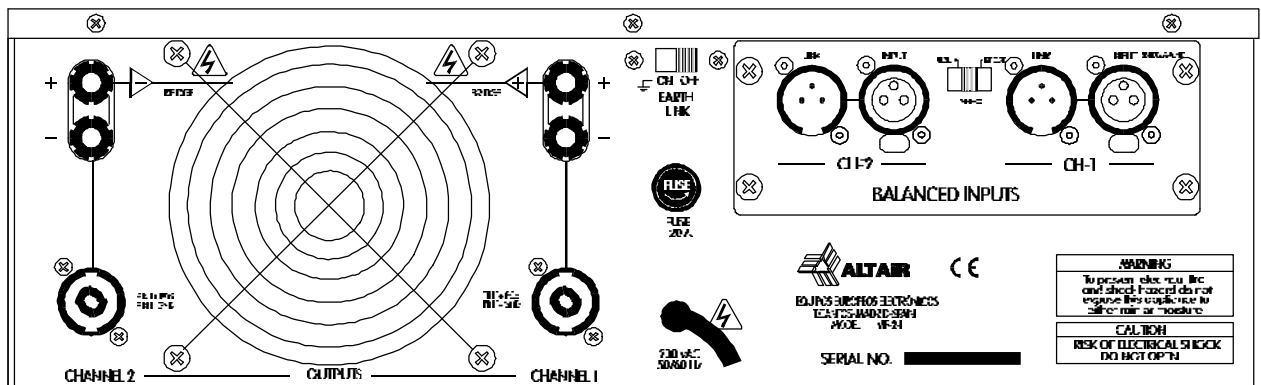
**MF16 AND MF24 REAR PANEL**

OUTPUT POWER SPEAKON® CONNECTOR.



BINDING POST.

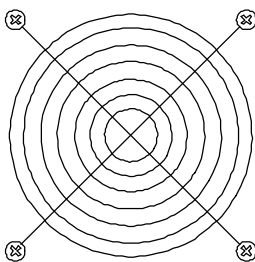

FAN (ONLY MF16 AND MF24).



FUSE HOLDER.



MAINS CORD.



EARTH LINK SWITCH.

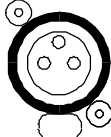

INPUT SIGNAL CONNECTOR XLR-3-31.



JACK 1/ 4" INPUT SIGNAL LINK CONNECTOR.  
(ONLY MF8 AND MF12).

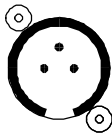



XLR-3-32 INPUT SIGNAL LINK CONNECTOR.  
(ONLY MF16 AND MF24).



MONO/ STEREO/ BRIDGE SWITCH.

### 3. WORKING PRECAUTIONS

- The manufacturer cannot be held responsible for any damage which is incurred by not using the power amplifier in compliance with the warranty or working precautions.
- **DANGER:** High voltage inside the amplifier. ! Do not open !. The power amplifier doesn't contain parts that can be repaired by the user. The power amplifier could have electric power stored in their interior even disconnected it from the mains. 
- **CAUTION:** Protect the power amplifier from the rain and moisture. Ensure that no objects or liquids enter it. If liquid is spilled into the power amplifier, disconnect the power amplifier from the mains and consult a qualified service technician. 
- Don't place the power amplifier close to sources of heat. Also make sure that the front and the rear panel there are free of obstructions, since the fan could not work properly and cause the thermal protection work.
- **DANGER:** The power amplifier output connectors could have high voltage. Make sure of turning off the power amplifier before handling on these output connectors.

### 4. INSTALLATION

#### UNPACKING

Before leaving from factory, each power amplifier was carefully inspected and tested. Unpack and inspect the power amplifier for any damage that may have occurred during shipment. If any damage is found, doesn't connect the power amplifier to the mains, notify the salesperson immediately, because the unit must be inspected by a qualified service technician.

Save the original packing, you could use if you need to transport the power amplifier.  
**NEVER SHIP THE POWER AMPLIFIER WITHOUT IT'S ORIGINAL PACKING.**

#### MOUNTING

It is always advisable mount the power amplifiers in rack, either for mobile or fixed installations, for protection, safety, aesthetics, etc.

The MF series power amplifiers are designed for standard 19" rack mounting, and occupy 2u (MF8 and MF12) or 3u (MF16 and MF24) high rack space .

Due to the weight of the unit, it should be securely fastened at the front and the back of the cabinet. If the racks are carriage ones, it is advisable that have trays in order to allow the power amplifier to rest on its base and in an elastic cradle, if possible. It is advisable, leave a separation space between amplifiers and other units in order to facilitate its cooling, upon mounting the amplifier in a rack.

In the mounting, either fixed or in rack, the cooling vents placed in the front panel (MF8 and MF12 also in the rear panel) and the fan, placed in the rear panel (only for MF16 and MF24) should be free, so that the air circulates freely, and the amplifier could have a better heat dissipation. In the same way, make sure that there are no heat sources near the front cooling vent, because the fan exhaust cool air through this vent.

Also, the mains transformer of the models MF16 and MF24, has a cooling vent in the left side of the power amplifier. This cooling vent may correspond with another one in the rack.

### CHANGING THE FUSE

The power amplifiers are designed to work with slow blow fuses of 6x32, whose values in order to work with a mains voltage of 230V 50-60 Hz are specified in the following list:

MODELS	FUSE (230V. 50-60 Hz)
MF8	T8A.
MF12	T12A.
MF16	T16A.
MF24	T20A.

- 1 Make sure that the power amplifier is disconnected from the mains.
- 2 At the power amplifier rear panel is placed the fuse holder. Unscrew the most external part of the fuse holder.
- 3 Upon unscrewing the most external part of the fuse holder, the fuse will appear. Remove it and change for new one.
- 4 Screw the external part of the fuse holder.

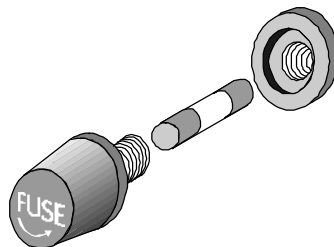

**CAUTION:** Always make sure upon changing the fuse, that this is the adequate.

### CONNECTING TO THE MAINS

The connection of the power amplifier to the mains takes place by means of a three-wire cord provided by the factory. The European standard color code is: Brown-Live, Blue-Neutral and Yellow/Green-Earth, keeps in mind this mains configuration, whenever handle the power amplifier plug.



In the connection of several devices to the same AC distribution board and extension cables, keeps in mind the maximum current of the power amplifier, and make sure that the mains connector, as well as the AC distribution board, are of enough current capacity, since could take place in the mains connector, and in the same AC distribution board a overheating, with the risk of fire and/or short circuit. The following list shows the maximum current requirement of the different models of power amplifiers:

MODELS	MAXIMUM CURRENT REQUIREMENT
MF8	6A.
MF12	10A.
MF16	14A.
MF24	18A.

- ❶ Make sure that the power amplifier power switch, is at position 0 (turned off).
- ❷ Insert the male connector of the three-wire cable into the mains plug.
- ❸ Turn on the power amplifier power switch. Right now the power amplifier will turn on.

**CAUTION:** Make sure that the mains voltage is 230V. 50-60 Hz., as well as their fuse is the adequate.

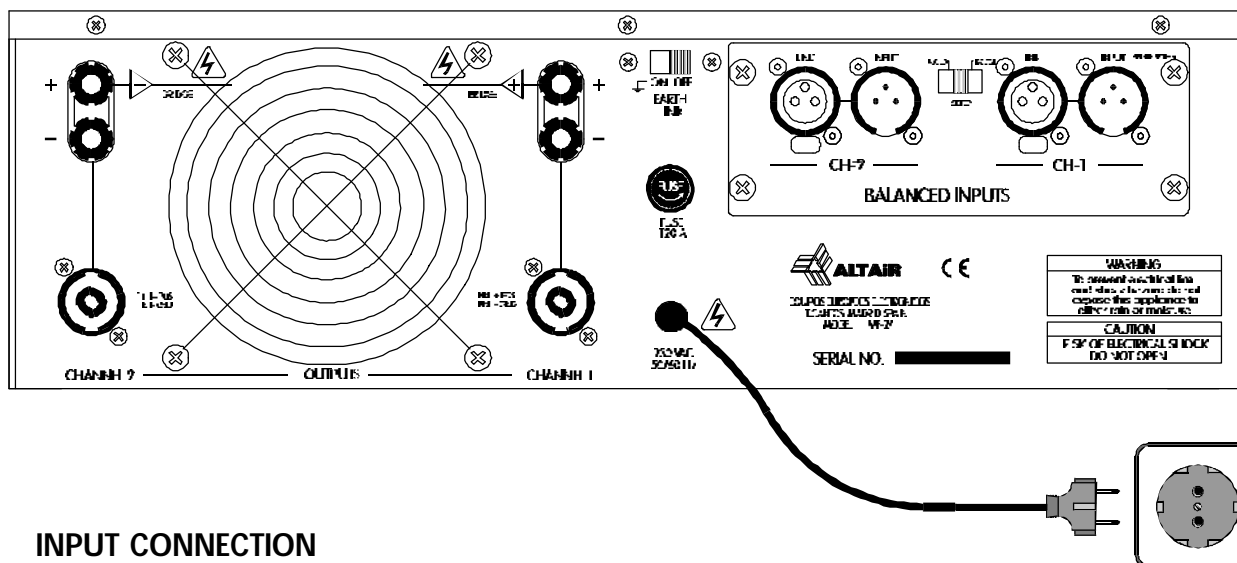

## INPUT CONNECTION

Each power amplifier's channel incorporates one XLR-3-31 female connector. The inputs are balanced, with a nominal impedance of 20 K $\Omega$  (10 K $\Omega$  unbalanced). On the other hand, the amplifier according to models has two JACK connectors 1/4" (MF8 and MF12) or two XLR-3-32 males connectors (MF16 and MF24), one per channel (LINK) that allows us to link the input signal from the power amplifier, to other units. The XLR male connectors and those of LINK are internally wired in parallel.

The input connections depends on two factors, the first is the type of input signal balanced or unbalanced, and the second the ground configuration of the sound source (floating or ground-referenced). The next pictures shows some of the different possibilities of connection, relying on the type of input signal, balanced or unbalanced and according to the ground configuration of the equipment (floating or ground-referenced).

**UNBALANCED INPUT:** This type of connection will be used when the sound source doesn't provide balanced output. If it is possible, will be employed the connection type 1.

1) Using twin-lead shielded cable:

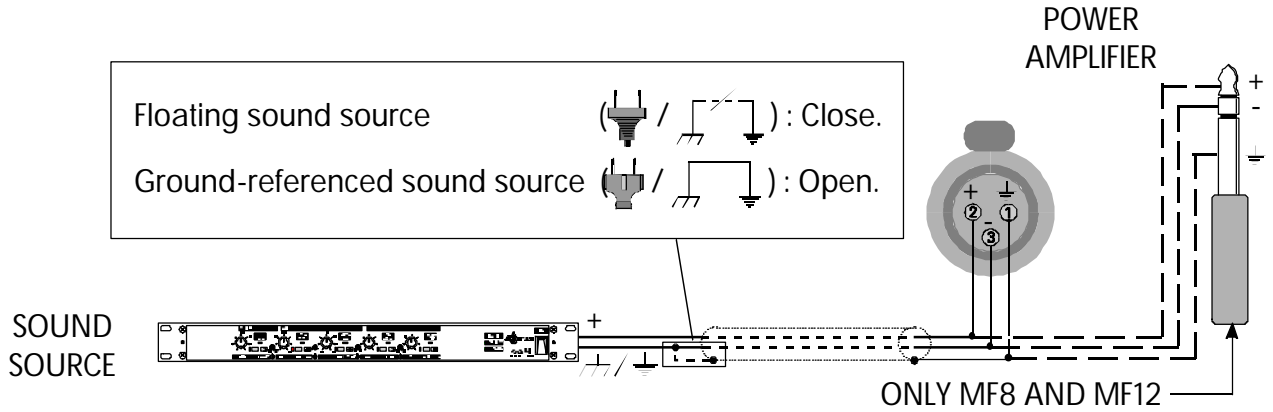

2) Using single conductor coax cable:

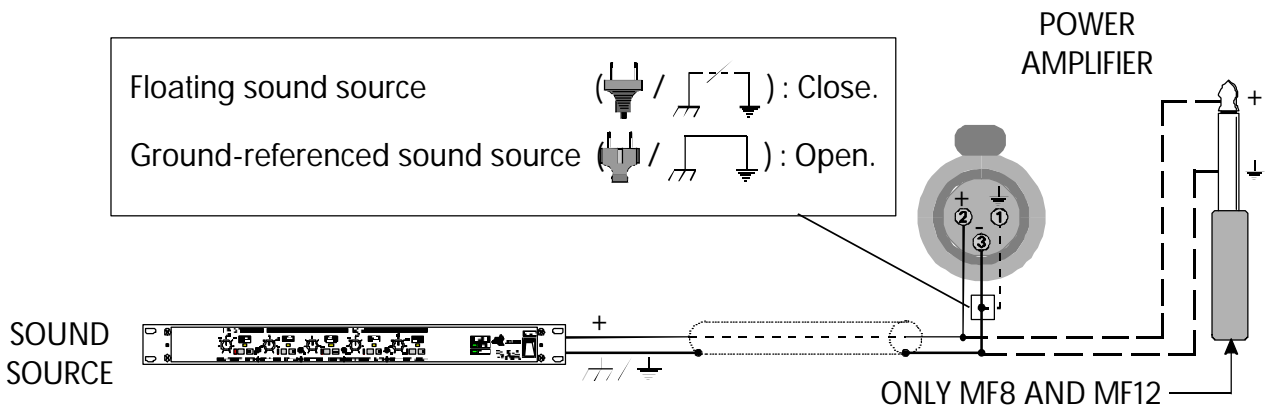

**BALANCED INPUT:**

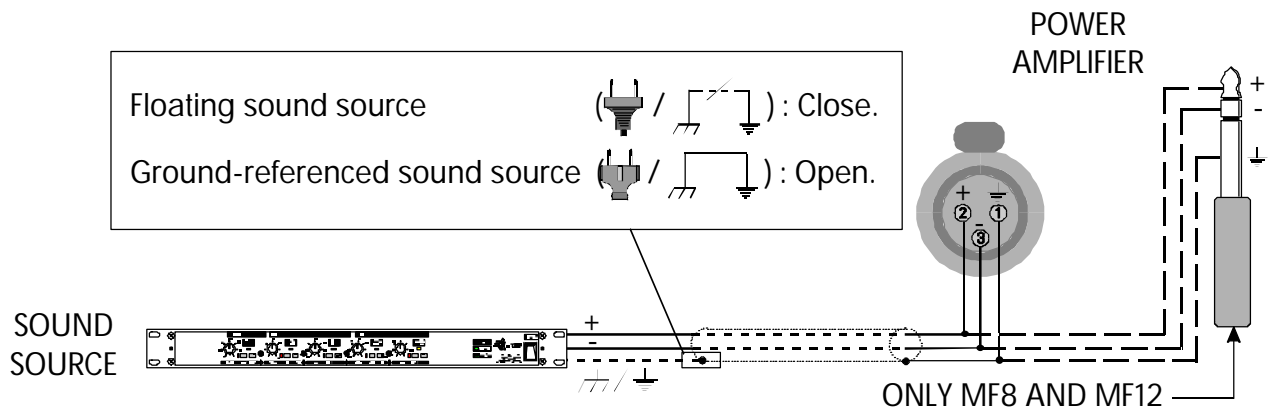





**NOTE:** The previous pictures, has been carried out supposing that the power amplifier is configured in the standard A.E.S.: pin 2 of the XLR connector as positive (later on will explain how changing this power amplifier configuration). If the power amplifier is configured with the pin 3 of the XLR connector as positive, change the pin 2 by the 3 in the previous pictures.

## OUTPUT POWER CONNECTION. MODES OF OPERATION

Each channel includes a pair of five-way binding post and a SPEAKON® connector. These connectors are wired inside in parallel. The red binding post is positive and the black is ground. The SPEAKON® connector, following NEUTRIK recommendations, has the next polarity: PIN 1+ positive, and PIN 1- ground. Keep in mind the polarity upon connecting the speakers since change the a speaker polarity of a system reduces the output power of the power amplifier, upon remaining this speaker with other phase with regard to the others.

In the output connection it is necessary to keep in mind a series of important precautions in order to don't produce an accidental short circuit or a possible damage in the equipment:

- Consider the power-handling capacity of your speakers before connecting it to the power amplifier. Equipos Europeos Electrónicos is not liable for damage occurred by the connection of speakers to the power amplifier with less nominal power that the power amplifier.
- Turn off the power amplifier and turn down the input attenuators, whenever takes place a output power connection. The output power connectors could have high voltage, with the rising danger of short circuit. 
- Never put the output power connectors in parallel. This connection doesn't increase the power and could cause the break of the power amplifier. 
- Do not connect the power amplifier output connectors to the output connectors of any other power amplifier. This connection could cause the break of one or both power amplifiers. 
- Do not connect the output connector ground (black binding post or PIN 1- of the SPEAKONr connector) to input connector ground (PIN 1 of the connector XLR-3-31 or sleeve of the Jack connector 1/ 4" in the case of the models MF8 and MF12). This could create a ground loop and could cause feedback oscillations. 
- Use loudspeaker cables capable to resist the output current of the power amplifier. The selection of a good loudspeaker cable, with a good quality and an adequate diameter is very important, and is often one of the things that less is kept in mind. 

The next list shows us the maximum output currents of the power amplifiers according to the model:

MODELS	MAXIMUM OUTPUT CURRENT
MF8	16A.
MF12	19A.
MF16	23A.
MF24	28A.

There are many factors that determine the loudspeaker cable diameter: the length of the cable, the type of signal that is going to circulate for it, the output power of the power amplifier etc. A cable with high resistance, reduces the damping factor, limiting the power amplifier capacity for control to the speakers accurately.

The possible output connections, depends on the configuration of the switch MONO/ STEREO/ BRIDGE of the power amplifier:

**CAUTION:** Do not change the configuration of MONO/STEREO/BRIDGE switch unless the power amplifier is first turned off. Before turn on the power amplifier, make sure that the mains, input and output connections are correct. If doesn't follow these recommendations, could cause a power amplifier and/or loudspeakers breakdown.

**STEREO MODE OPERATION:** In this mode the two channels of the power amplifier are totally independent, for what the two inputs signal, and the two power outputs will be wiring independently. In order to configure the power amplifier in STEREO mode, turn the amplifier off, slide the MONO/ STEREO/ BRIDGE switch to the center position, and wire the input and output connections according to the next picture:

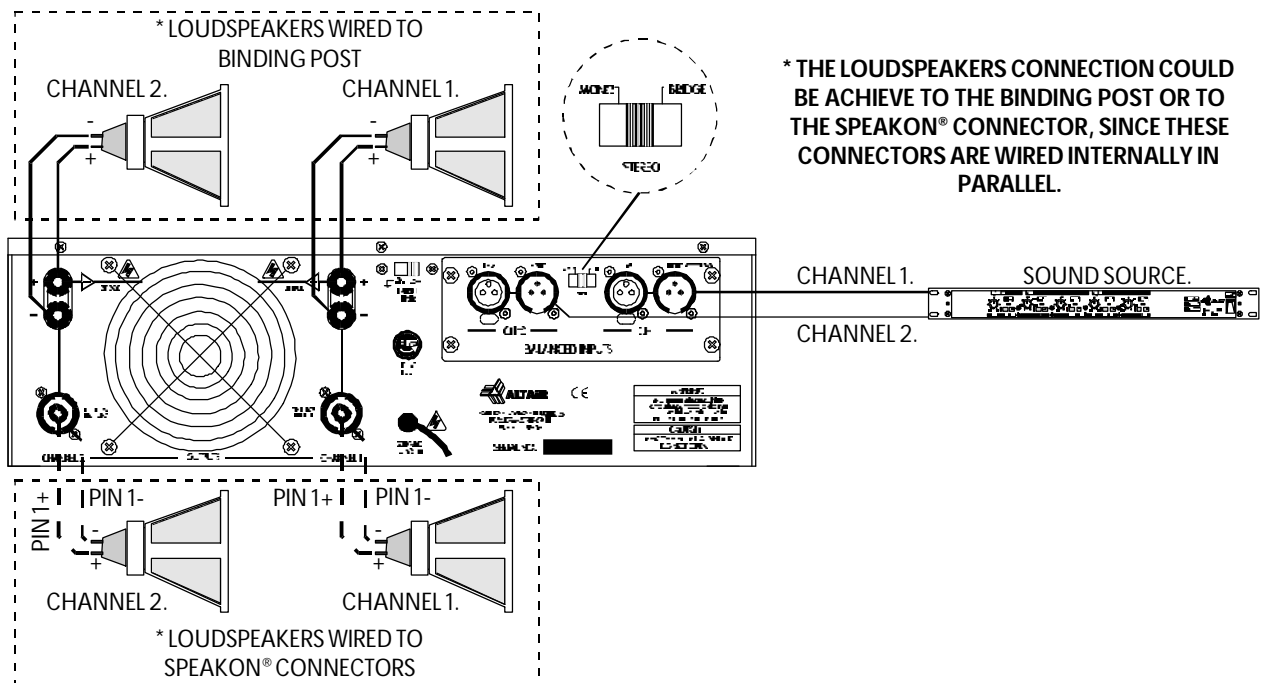

**MONO MODE OPERATION:** In the mode MONO, the input signal should be carried out for one any of the XLR connectors or Jack 1/ 4" (only for MF8 and MF12) of the CHANNEL 1 (CH1). The input signal is routed to both channels, being the power outputs totally independent. In the models MF16 and MF24, the input attenuators could configure internally, so that the CH1 input attenuator governs both channels, or that each input attenuator affects to their corresponding channel (for more information consults the section SPECIAL OPERATIONS - INPUT ATTENUATORS CONFIGURATION IN MONO MODE), in the models MF8 MF12 the input attenuators of the two channels are totally independent in MONO mode. In order to configure the power amplifier in MONO mode, turn the amplifier off, slide MONO/ STEREO/ BRIDGE switch toward the left (as you face the rear panel), and wire the input and output connections according to the next picture:

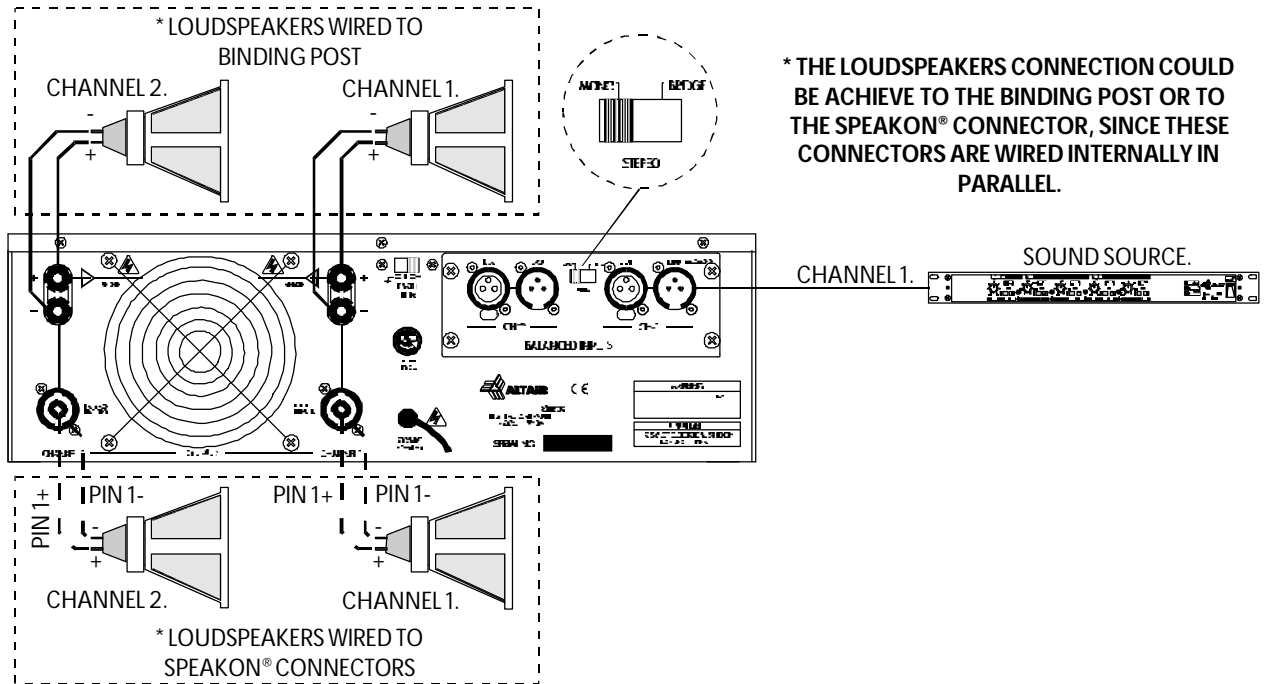

**BRIDGE MODE OPERATION:** In BRIDGE mode, the input should be inserted for any of the XLR connectors or Jack 1/ 4" (only for MF8 and MF12) of CH1. In this mode the power of the two channels will be added over a single load. The CH1 input attenuator controls both channels, remaining the CH2 input attenuator disabled. The output in BRIDGE mode, must be taken between the red binding post (positive pole is the red binding post of CH1 and the ground, the red binding post of CH2) or for the SPEAKON® connectors (positive pole is the PIN 1+ of CH1 and the ground is the PIN 1+ of CH2). To put the power amplifier in BRIDGE mode, turn the power amplifier off, slide the MONO/ STEREO/ BRIDGE switch toward the right (as you face the rear panel), and wire the input and output connections according to the following picture:

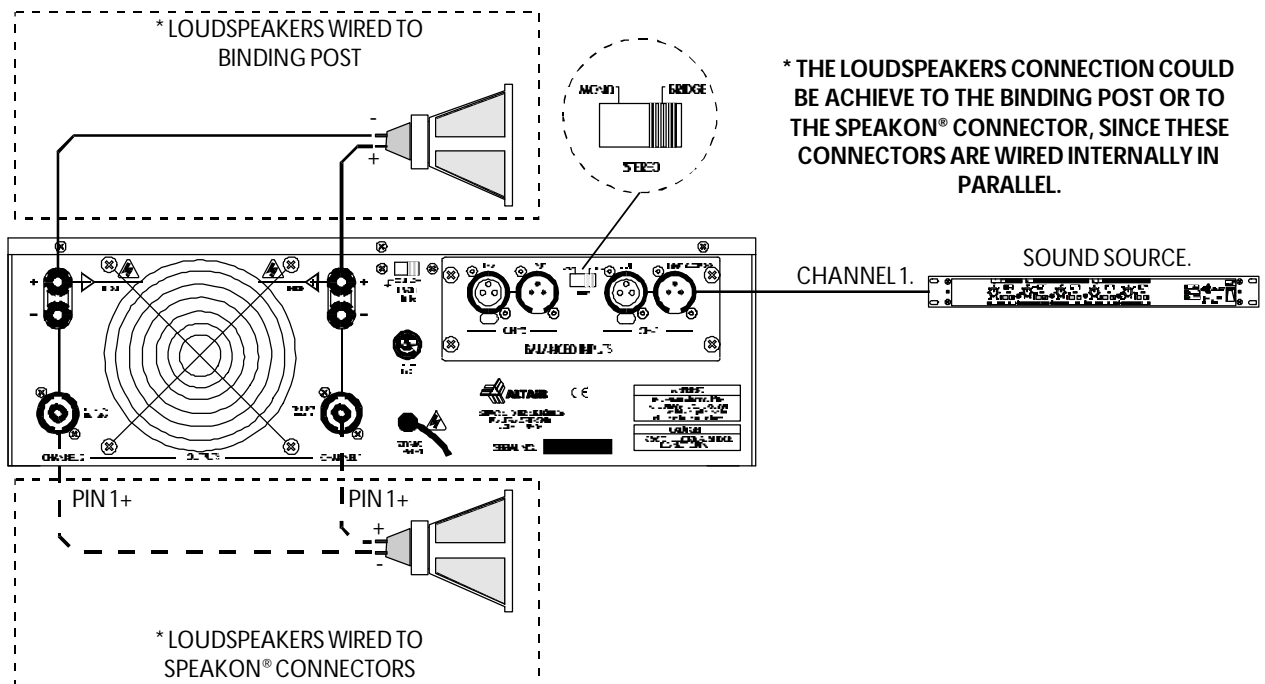

## EARTH LINK

In some installations, it might be necessary to isolate the power amplifier electric ground, from the system mains earth, in order to avoid ground loops, that could generate unwanted noises, for this reason, the power amplifier provides an EARTH-LINK switch placed at the rear panel in order to lift the mains earth from the power amplifier electric ground.



MAINS EARTH LINKED WITH THE POWER AMPLIFIER ELECTRIC GROUND.



MAINS EARTH LIFTED FROM THE POWER AMPLIFIER ELECTRIC GROUND.

**CAUTION:** Sometimes, lift the mains earth, using a ground-lift connector, the one which undoes the ground loop also, but this is very dangerous, since if for any circumstance part of the mains signal is derived to the chassis, could cause a short circuit through our body, upon having eliminated one of the working precautions of the unit. For this circumstance **NEVER** lifts the mains earth (use the EARTH-LINK switch of the unit) in order to avoid possible accidents.

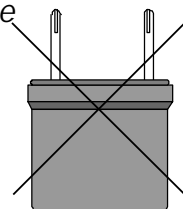



## 5. OPERATION

### POWER UP

Plug in all input and output connectors (following the recommendations of the sections INSTALLATION - INPUT CONNECTION AND INSTALLATION- OUTPUT CONNECTION). Ensure that both power amplifier's input attenuators are turned fully counter-clockwise to the  $\infty$  position. At this time could switch the power amplifier on.



Upon switch the power amplifier on, acts the delay turn on system, that minimizes the effect of the transitory currents in the transformer. In a few seconds, the delay turn on system stops working (a RELAY will be listened to). In the models MF16 MF24, if this circuit doesn't work correctly, would light the ERROR indicators  of both channels at the same time, and the power amplifier would not start up, at the same time the ON/STBY indicator  would not pass to green colour.

When turning on a rack of power amplifiers they should be switched on individually. The practice of leaving all power amplifiers in a rack switched on and powering up the whole rack by connecting it to the mains is dangerous and likely to blow the mains fuse of the rack power supply, if with good approach, the rack has one. In a rack of power amplifiers, switch the power amplifiers on one by one.

Note that upon switching the power amplifier on, the ON/STBY indicator  lights in red (indicating that the power amplifier is cutting the input signal), and after a few second change to green (indicating that the power amplifier connected the input signal). At this time could turn on the power amplifier input attenuators.

## INPUT ATTENUATORS

Each power amplifier channel has a input signal attenuator, gauged. The calibration is measured between  $\pm 0.5$  dBu.

The input attenuators are independent for each channel in STEREO mode. In the models MF16 and MF24 in mode MONO it is selectable the control of the input attenuators over the channels (independent or both channels dependent on the CH1 input attenuator) (for more information see section SPECIAL OPERATIONS - INPUT ATTENUATION CONFIGURATION IN MONO MODE).

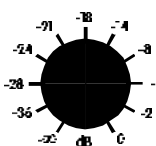



In the models MF8 and MF12 in mode MONO, the input attenuators are independent for each channel. In mode BRIDGE both channels depend on the CH1 input attenuator.

## BRIDGE MODE INDICATOR

The red BRIDGE LED  illuminates when the power amplifier is working in BRIDGE mode.

## CLIP INDICATORS (INPUT SIGNAL OVERLOAD)

The CLIP red LED , illuminates when the power amplifier starts to saturate, moreover, if the limiter is ON, this LED indicates that the circuit limiter starts to work (for more information see section SPECIAL OPERATIONS- LIMITER CONFIGURATION). The CLIP indicators  are independent in each channel, and indicates a real saturation, by comparing input and output continuously, and are independent of the mains voltage.

The CLIP indicators  also illuminates when there is a output short-circuit or when a protection (DC or thermal) of the power amplifier disconnects the input, whenever one input signal is being introduced to the power amplifier.

To make the loudspeakers life longer, avoid this situation of overload during for extended periods of time.

If the input signal level is too high, don't turn the power amplifier limiter off, because it is an efficient protection for the loudspeakers.

In general, the loudspeakers resist high peaks of instantaneous power, but when exposed power to extended saturations they lose any guarantee of good operation.

The saturation measuring circuit is sensitive to peaks, it has a quick attack time and a slow release time.





## SIGNAL INDICATORS

The SIGNAL green LEDs  illuminates when the output signal of the corresponding channel reaches 25 dBu before saturation.



These LEDs indicate signal presence in the power amplifier input.

This SIGNAL  measurement circuit is sensitive to peaks, it has a quick attack time and a slow release time to indicate the average power.



## ERROR INDICATORS





The power amplifier load protection circuit, work when a continuous voltage appears in the power amplifier output connectors, shortcircuiting the power amplifier output, disconnecting the input signal (the ON/STBY LED  of the corresponding channel illuminates on red) and indicating this situation with the ERROR red LED  of the corresponding channel. When the continuous voltage disappear, the load protection circuit automatically release the power amplifier's output shortcut, connect the power amplifier's input, the ERROR red LED  turns off and the ON/STBY LED  turns green. By this shortcut in the power amplifier's output, if the continuous voltage remains, the thermal protection could activate. This protected circuit is know by CROW-BAR.

The power amplifier has an independent load protection circuit and an ERROR  indicator for each channel.

How spoke previously in the section OPERATION - POWER UP, the ERROR red LED , could also indicate a failure in the delay turn on circuit in the models MF16 and MF24, in that case would light the ERROR red LED  of both channels at the same time. The failure in the delay turn on circuit could take place for three circumstances, a very low mains voltage, in which case it is necessary to solve the problem in the mains and power up the power amplifier again, a shortcut in the power amplifier, or the break of the own delay turn on circuit. In these last two cases, should order to revise the power amplifier for a qualified technician.

## THERMAL INDICATORS

When the power amplifier output transistors reach the 90°C, begin to work the thermal protection circuit, lighting the THERMAL orange LED  of the corresponding channel. The thermal protection, disconnects the power amplifier input signal, turning red the ON/STBY LED  of the corresponding channel. This only happens under the most severe conditions of continuous overload; in such a case, it is essential to localize and to rectify the cause of this overheating condition. The thermal protection circuit returns automatically to its normal position when the power amplifier output transistors drops under the security of security, connecting the input signal again, and turning green the ON/STBY LED .

The mains transformer, has a thermal breaker, which protect it from overheating. When work this thermal breaker, the power amplifier input signal of both channels is opened, changing to red the ON/STBY LED  of both channels and start flash the THERMAL orange LED  of both channels, indicating that the mains transformer has reached the 100°C. As in the case of the power amplifier output transistors, it is essential to localize and rectify the cause of this overheating condition. When the mains transformer temperature drops under the security level, the thermal protection circuit returns automatically to their normal condition connecting the power amplifier input signal of both channels again, turning off the THERMAL LED , and changing to green the ON/STBY LED  of both channels.

## ON/STBY INDICATORS

The ON/STBY LED indicates the connection or disconnection of the power amplifier input signal. The three colors LED ON/STBY  illuminates in red when the power amplifier input signal is disconnected and it illuminates in green when the power amplifier input signal is connected.





Therefore, whenever this indicator is in red, will indicate us that the power amplifier input signal is disconnected, and the power amplifier is not operative at that moment. This occurs when the power amplifier is turned on, and when the ERROR or THERMAL protections are activated.

The power amplifier has two ON/STBY LED  indicators, one per channel.

## POWER SWITCH

The power switch of the models MF16 and MF24 has a thermal breaker inside. This thermal breaker acts interrupting the mains supply of the power amplifier, when the mains current is high or equal to 20 amperes. When the thermal breaker work, the power switch is placed in the OFF position, for what it is necessary to turn on the power amplifier in order to use it again. It is important to know what circumstance happen and correct this, before power up the power amplifier again.

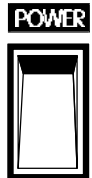

The models MF8 and MF12 incorporates power switches without thermal breaker.

## FAN

The power amplifier includes a thermally controlled system, which continuously regulates the fan speed depending on, the heat energy it has to evacuate. This variable speed circuit, avoids abrupt changes of temperature and substantially extends the working life of the components builds in. At power amplifier turn on, the fan rotates with his top velocity, in order to exhaust the maximum dust possible. Soon after, the fan's speed drops to normal. The power amplifier fan rotates with its top velocity also, in an overheating situation (when a thermal protection work) so that the heat drops under the security level quickly.

In the models MF16 and MF24, the fan is protected with a grid, that avoids objects inserted between its wheels, as well as a possible accident with the same. It is important that nothing obstruct the airflow to the fan at any time.

The models MF8 and MF12 have the fan inside, for what doesn't have protection grid, however incorporates some cooling vents in the rear panel for which the air is evacuated, for what it is important make sure that the cooling vents are always free so that the air could circulate with freedom.

## LOAD IMPEDANCES

The power amplifiers MF series, are designed to drive a  $2\Omega$  or higher load impedances load in MONO or STEREO mode ( $4\Omega$  or higher in mode BRIDGE), without current limiting. However, using several speakers in parallel in order to get these  $2\Omega$  it could be an impedance of load of less than  $2\Omega$ .

The speaker load impedance is variable with the frequency, and in fact, connect four speakers in parallel, with a nominal impedance of  $8\Omega$  each one, gives a less impedance like result that the theoretical  $2\Omega$ . Therefore high signal levels associated with a compressed signal source can cause the power amplifier to reach its thermal limits and disconnects its load.



If you want that your power amplifier works with  $2\Omega$  load impedances, you should consult the speaker impedance curves that is going to connect and study each case in particular. It is very advisable enable the power amplifier limiter, whenever it is working with  $2\Omega$  load impedances.

The ability to drive  $2\Omega$  load impedances is primarily intended to insure that the power amplifier will never be pushed beyond its current limits when driving nominal  $4\Omega$  load impedances that may reach a minimum of only  $2\Omega$  at some frequencies.

When the power amplifier is working in BRIDGE mode, the load impedance must be of  $4\Omega$  or higher, with the same consideration that in MONO or STEREO mode with  $4\Omega$  load impedance. This is because in BRIDGE mode, it is as if each channel is driving with the half load impedance.



## MAINTENANCE







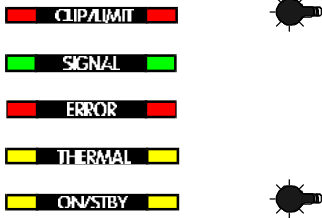

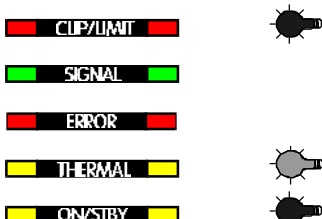
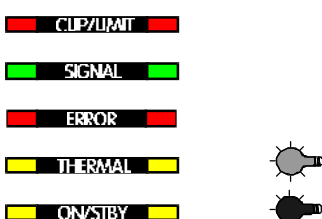































































Periodically, and in a technical service, should clean the dust and dirt accumulated inside the power amplifier, especially in the heatsinks, the fan and the cooling vents, with a vacuum cleaner or with an air-compressor gun. The dirt diminishes considerably the capacity of radiation and ventilation.

The input attenuators (potentiometers) are sensitive to the dust accumulated, and therefore for they will be cleaned with an air compressor gun or be changed if they are very wrong.

**NOTE:** *Equipos Europeos Electrónicos don't recommend the use of spray cleaners because they could damage the lubricant layer of the potentiometers. Use compressed air to clean them or replace with similar parts.*

**AMPLIFIER CONDITIONS**

INDICATORS	AMPLIFIER CONDITION
	<p>The power amplifier has just been turned on (it is still in the initial mute delay) and it is receiving an input signal. In this case the ON/STBY indicators of both channels would be illuminated in red.</p> <p style="text-align: center;">OR</p> <p>A protection was activated (ERROR or THERMAL) and this condition has been corrected. The power amplifier is receiving an input signal. In this case would be illuminated in red the ON/STBY indicator of the channel in which the protection has been activated.</p>
	<p>The power amplifier has just been turned on (it is still in the initial mute delay) and it is not receiving an input signal. In this case the ON/STBY indicators of both channels would be illuminated in red.</p> <p style="text-align: center;">OR</p> <p>A protection was activated (ERROR or THERMAL) and this condition has been corrected. The power amplifier is not receiving an input signal. In this case would be illuminated in red the ON/STBY indicator of the channel in which the protection has been activated.</p>
	<p>The thermal protection of one channel has been activated. In this case, the THERMAL indicator (amber) and the ON/STBY indicator (red) of the channel in which the protection has been activated would be illuminated. The power amplifier is receiving an input signal.</p> <p style="text-align: center;">OR</p> <p>The transformer thermal protection has been activated. The THERMAL indicators (amber) of both channels will be blinking and the ON/STBY indicators of both channels will be illuminated. The power amplifier is receiving an input signal.</p>
	<p>The thermal protection of one channel has been activated. In this case, the THERMAL indicator (amber) and the ON/STBY indicator (red) of the channel in which the protection has been activated would be illuminated. The power amplifier is not receiving an input signal.</p> <p style="text-align: center;">OR</p> <p>The transformer thermal protection has been activated. The THERMAL indicators (amber) of both channels will be blinking and the ON/STBY indicators of both channels will be illuminated. The power amplifier is not receiving an input signal.</p>

INDICATORS	AMPLIFIER CONDITION		
 CLIP/LIMIT   SIGNAL   ERROR   THERMAL   ON/STBY 	The DC protection of one channel has been activated. In this case, the ERROR indicator (red) and the ON/STBY indicator (red) of the channel in which the protection has been activated will be illuminated. The power amplifier is receiving an input signal.		
 CLIP/LIMIT   SIGNAL   ERROR   THERMAL   ON/STBY 	The DC protection of one channel has been activated. In this case, the ERROR indicator (red) and the ON/STBY indicator (red) of the channel in which the protection has been activated will be illuminated. The power amplifier is not receiving an input signal.		
 CLIP/LIMIT   SIGNAL   ERROR   THERMAL   ON/STBY 	<b>MF16 AND MF24 ONLY.</b> The delay turn on protection circuit has been activated. The ERROR indicators (red) of both channel will be illuminated. This could happen for a very low mains voltage or for a failure or overheating on the delay turn on circuit, when the amplifier has been turned on.		
 CLIP/LIMIT   SIGNAL   ERROR   THERMAL   ON/STBY 	There is no power to the amplifier, either because it is not plugged or because the power switch is in the OFF position.		
 CLIP/LIMIT   SIGNAL   ERROR   THERMAL   ON/STBY 	The channel with this indicator status is not receiving an input signal, but is ready in order to receive it.		
 CLIP/LIMIT   SIGNAL   ERROR   THERMAL   ON/STBY 	Normal operation. The channel with this indicator status is receiving an input signal, and amplifying it.		
 CLIP/LIMIT   SIGNAL   ERROR   THERMAL   ON/STBY 	The channel with this indicator status is receiving an input signal too high. If the limiter is connected, it will be working, and if it is not connected, the output signal will be saturated.		
INDICATORS	RED	AMBER	GREEN
			

## 6. SPECIAL OPERATIONS

In order to configure some of the power amplifier possibilities it is necessary to open it, removing the nine screws of their upper cover.

**NOTE:** This type of operations, takes place with the unit open, for what it should be carried out by a qualified technician.

**DANGER:** Before opening the amplifier, disconnect it of the mains. It is important indicate that although the unit is power out (with the power switch in 0 position), if it continue connected to the mains there is different parts of the unit that are subjected to high voltage.

**CAUTION:** Protect the power amplifier from the rain and moisture, mainly if it is open. If liquid is spilled into the power amplifier, disconnect it from the mains and consult a qualified service technician.

In the models MF16 and MF24, all the internal configurations take place on the power amplifier input board (INPUT MF-1600/ALTAiR- 054) shown in the next figure. This board is located in the upper left corner of the rear panel (as you face the front panel).

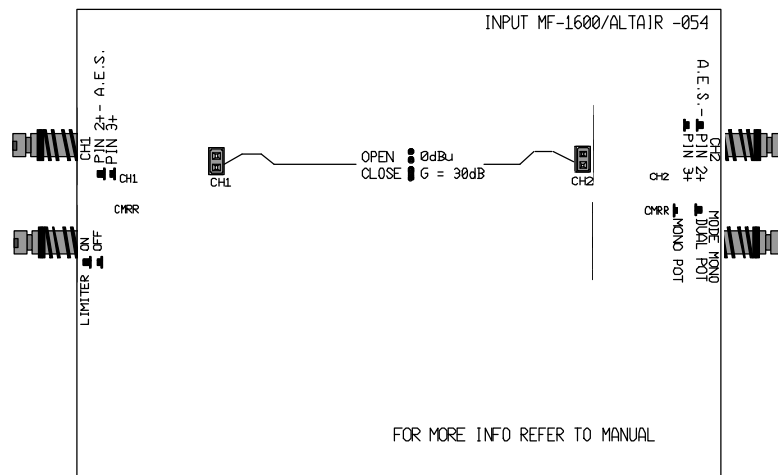

In the models MF8 and MF12 the XLR polarity and the input sensibility configurations takes place on the power amplifier input board (INPUT MF8/12 ALTAiR- 072) shown in the next figure. This board is located in the upper left corner of the rear panel (as you face the front panel).

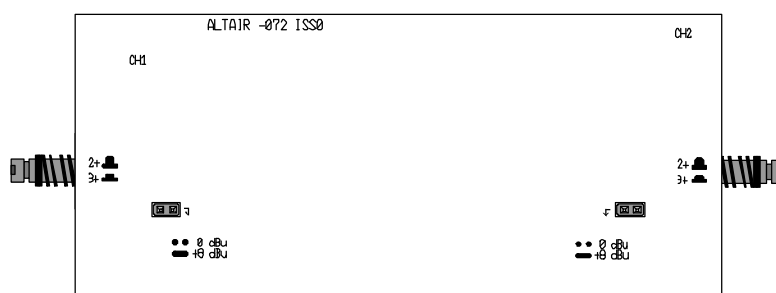

The limiter configuration in the models MF8 and MF12 takes place in the driver board (DRIVER MF8/12 ALTAIR- 074). Part of this board is showed in the next figure. This badge is located parallel to the power amplifier bottom plate. The driver board is wide, occupying almost the whole width of the power amplifier. The limiter configuration switch is close to the rear panel, in the center a little toward the left (as you face the front panel).

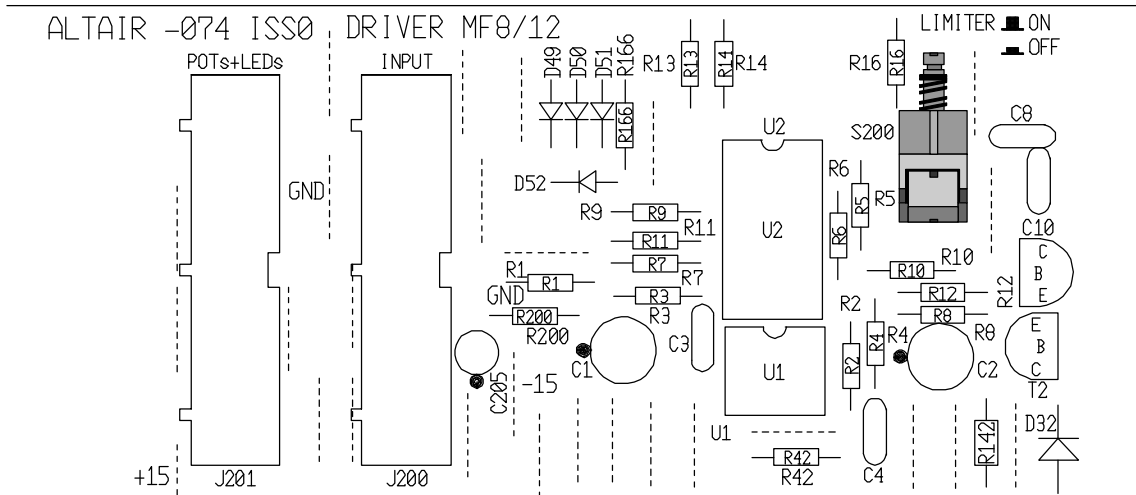

**NOTE:** The factory configuration of these controls, is marked in the rear panel of the power amplifier. If you change this configuration, write it in the white box placed in the power amplifier's rear panel to avoid confusions.

### CHANGING XLR INPUT CONNECTORS POLARITY



The XLR input connectors, could configure with the PIN3 positive or with the PIN 2 positive (A.E.S. recommendation). With the polarity switch pushed, the XLR input polarity is: PIN 3 positive, PIN 2 negative, PIN 1 ground. If the polarity switch is not pushed, the input XLR polarity is: PIN 2 positive, PIN 3 negative, PIN 1 ground.

Each channel has their own polarity switch, for what you could configure each channel independently. This is true whenever the power amplifier works in STEREO mode, since if it is working in MONO or BRIDGE mode, the XLR input polarity configuration of the channel 2 (CH2) will remain disabled, remaining as valid configuration the channel 1 (CH1) one.

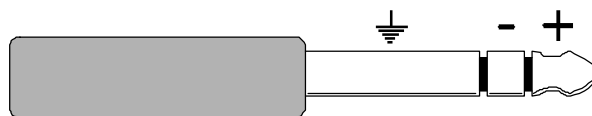
**NOTE:** In the models MF8 and MF12 that have Jack 1/ 4" as input connector besides the XLR-3-31, the polarity configuration of the XLR connector doesn't affect the polarity configuration of the Jack 1/ 4," always being this: TIP-> positive, RING-> negative, SLEEVE-> ground:

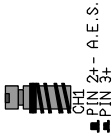

The factory setting of the XLR input polarity is: PIN 3 positive, PIN 2 negative and PIN 1 ground. This configuration is same as the other ALTAIR power amplifiers to maintain the compatibility.

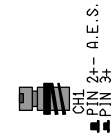
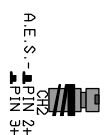
CH1	CONFIGURATION	CH2
(A.E.S.) 	PIN 1 - GROUND. PIN 2 - POSITIVE. PIN 3 - NEGATIVE.	
	PIN 1 - GROUND. PIN 2 - NEGATIVE. PIN 3 - POSITIVE.	

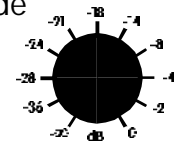

**INPUT ATTENUATOR CONFIGURATION IN MODE MONO (MF16 AND MF24 ONLY)**

The input attenuators (potentiometer), may be configured in MONO mode for the models MF16 and MF24. With the switch of configuration placed in the input board not pushed, the input attenuators will be independent for each channel (DUAL POT), and with this switch pushed, the input attenuator of the channel 1 (CH1) will control both channels at the same time (MONO POT).



In the models MF8 and MF12 this input attenuator configuration don't exist, the input attenuators are always independent for each channel.

The factory configuration is with the input attenuators independent (DUAL POT).

DUAL POT. (Input attenuators independent for each channel).	
MONO POT. (Input attenuator of channel 1 (CH1) controls both channels).	

**LIMITER ON/OFF**



The power amplifier's limiter reduces the input signal when the power amplifier starts to saturate, which avoids high saturation and loudspeakers damage.

It is very advisable use the limiter circuit, mainly in applications with 2Ω loads.

When the limiter ON/OFF switch is not pushed, the limiter is enable (ON). When this switch is pushed, the limiter is disable (OFF).

The limiter configuration (ON/OFF) affects to both channels of the power amplifier.

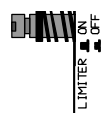
The factory configuration is with the limiter enable (ON).

	LIMITER ON (enable).
	LIMITER OFF (disable).

**NOTE:** Remember that in the models MF8 and MF12, this limiter configuration takes place in the driver board.

### INPUT SENSIBILITY/GAIN ADJUST

The power amplifier input sensibility may be configured with two jumpers, one for each channel. When the jumper of the channel that we want to configure is open (it is equal for both channels) the input sensibility (input level necessary in order to produce the maximum output level) is 0 dBu. With the jumper closed, the input sensibility is +8 dBu.

The factory configuration is with input sensibility 0 dBu.

**NOTE:** 0 dBu = 0.775 Volts; +8 dBu = 1.95 Volts.

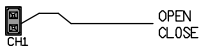
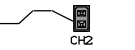
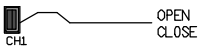
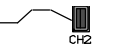
CONFIGURATION	CH1	CH2
Input sensibility = 0 dBu.		
Input sensibility = +8 dBu.		

The gain (times that the output signal is increased with regard to input signal), depends on the power amplifier model, as well as of the input sensibility configuration, in the next table is shown the gains according to the power amplifier model and his input sensibility configuration:

GAIN (dB)		
MODELS	INPUT SENSIBILITY	
	0 dBu (0,775 V).	+8 dBu (1,95 V).
<b>MF 8</b>	35	27
<b>MF 12</b>	37	29
<b>MF 16</b>	38	30
<b>MF 24</b>	40	32

The input sensibility could be configured in intermediates values, welding a resistor between the jumper pins. This is show in the next drawing:

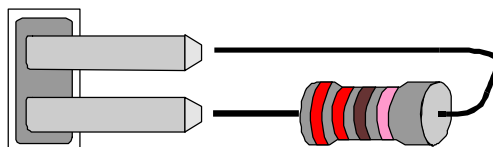



The different resistors in order to get input sensibilities between 0 dBu and +8dBu are shown in the next table:

<b>INPUT SENSIBILITY</b>	<b>RESISTOR (1%)</b>
+1 dBu (0,87 V).	39K2
+2 dBu (0,98 V).	16K9
+3 dBu (1,10 V).	9K09
+4 dBu (1,23 V).	5K76
+5 dBu (1,38 V).	3K57
+6 dBu (1,55 V).	2K05
+7 dBu (1,74 V).	1K02

## 7. DISTRIBUTED SYSTEMS APPLICATION (PUBLIC ADDRESS)

At the moment the standard of public address, use loudspeakers of 70.7 Volts and 100 Volts with different powers. The professional power amplifiers MF series could work with these public address systems. In order to use the power amplifiers in distributed systems, it is necessary to choose the voltage (and therefore the power amplifier model) of work and wire the loudspeakers in parallel with the power amplifier output, always keeping in mind that the sum of the loudspeaker powers placed in parallel with the power amplifier output should not never overcome the maximum acceptable power of the amplifier. The next table shows the voltages and powers with which the different power amplifier models could work:

<b>OUTPUT POWER Watts RMS 1KHz, THD+N 0,1%</b>			
<b>MODELS</b>	<b>Bridge mode</b>		<b>Stereo mode</b>
	70,7 V	100 V	70,7 V
<b>MF 8</b>	700 W	--	--
<b>MF 12</b>	--	1200 W	--
<b>MF 16</b>	--	--	--
<b>MF 24</b>	--	--	2x1200 W

## 8. TECHNICAL SPECIFICATIONS

TECHNICAL SPECIFICATIONS				
MODELS	MF8	MF12	MF16	MF24
<b>OUTPUT POWER IN WATTS</b> (RMS, 1 KHz, THD < 0,1%), [RMS, 1KHz, THD < 1%]				
Stereo mode: (per channel, with botch channel driven)	8Ω	240	360	720
	4Ω	400	600	1190
	2Ω	500	750	[1500]
Bridge mode:	8Ω	800	1200	2300
	4Ω	1000	1500	[3200]
Dynamic power EIA RS-490: (botch channel driven)	4Ω	460	700	1400
	2Ω	650	1000	1800
<b>TOTAL HARMONIC DISTORTION (THD+N):</b>	Less than 0,05% at rated output power at 1 KHz into 4 Ω.			
<b>INTERMODULATION DISTORTION</b>	<b>SMPTE:</b> - Less than 0,08% at 60Hz, 7KHz, 4:1 ratio, into 4Ω. at rated output power. <b>DIM-30:</b> - Less than 0,04% into 4Ω.			
<b>INPUT SENSIBILITY:</b> at rated output power (4Ω)	Internally adjusted with jumper: Open jumper: 0 dBv (0.775 V). Close jumper: +8dBv (1.95 V).			
<b>INPUT IMPEDANCE:</b>	Balanced: 20 KΩ. Unbalanced: 10KΩ.			
<b>COMMON MODE REJECTION RATIO (C.M.R.R.):</b>	Greater than 70 dB, 20 Hz to 10 KHz.; 90 dB at 50 Hz.			
<b>DAMPING FACTOR:</b>	Greater than 700 at 1 KHz into 8Ω.			
<b>HUM AND NOISE:</b> ("A" weighted):	Greater than 100 dB, 20Hz to 20KHz ref. full output.			
<b>FREQUENCY RESPONSE:</b>	20 Hz to 20KHz (-0,5 dB).			
<b>OUTPUT SLEW RATE:</b>	Limited by input TIM filter to 30 V/μs. Internally 60 V/μs.			
<b>CHANNEL SEPARATION:</b>	Greater than 65 dB at 1KHz.			
<b>INPUT CONNECTORS PER CHANNEL:</b>	XLR-3-31 Balanced. Jack 1/4" Balanced.		XLR-3-31 Balanced. XLR-3-32 Balanced.	
<b>OUTPUT CONNECTORS PER CHANNEL:</b>	Binding post and SPEAKON®.			
<b>INDICATORS:</b>	CLIP LED (one per channel). SIGNAL LED (one per channel). THERMAL LED (one per channel). ERROR LED (one per channel). ON/STBY LED (one per channel). BRIDGE LED.			
<b>COOLING:</b>	Forced air by continuous variable speed fan. Front to rear cooling.			
<b>PROTECTIONS:</b>	Electronic against short-circuit and open circuit. Thermal against output transistors and mains transformer overheating. DC out by solid state relay. Mains thermal breaker (MF16 and MF24 only). Delayed turn-on - Inrush transient.			
<b>POWER SUPPLY:</b>	115/230 Volts + 10%, -30%, 50/60 Hz.		230 Volts + 10%, -30%, 50/60 Hz. (115 Volts under request)	
<b>POWER REQUIREMENTS AT FULL OUTPUT:</b>	1500 V.A.	2000 V.A.	3000 V.A.	4000 V.A.
<b>NET/SHIPPING WEIGHT:</b>	16 Kg. / 20 Kg.	17 Kg. / 21 Kg.	29 Kg. / 33 Kg.	30 Kg. / 34 Kg.
<b>DIMENSIONS:</b>	483x89x384 m/m (19" x 2 u.).		483x133x384 m/m (19" x 3 u.).	
<b>RACK MOUNTING:</b>	450 m/m deep needed including external XLR's.			

**NOTE:** EQUIPOS EUROPEOS ELECTRÓNICOS S.A.L. reserves the right to modify the technical specifications without previous notice.

## 9. GRAPHS

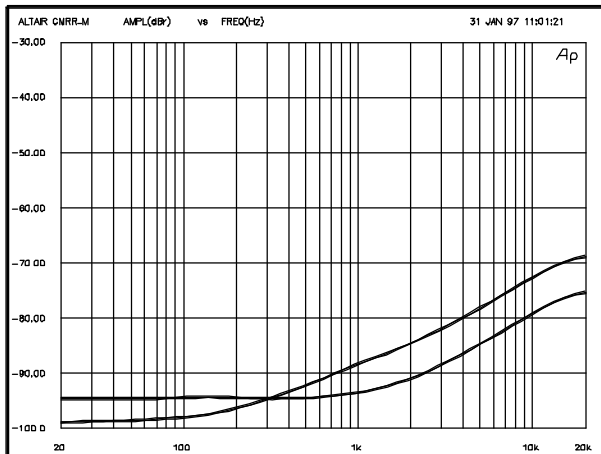

MF24: Typical common mode relation ratio (C.M.R.R.) versus frequency.

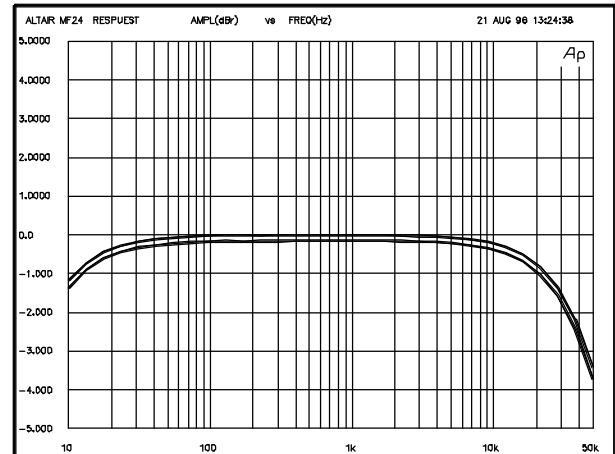

MF24: Frequency response at rated output into 4Ω.

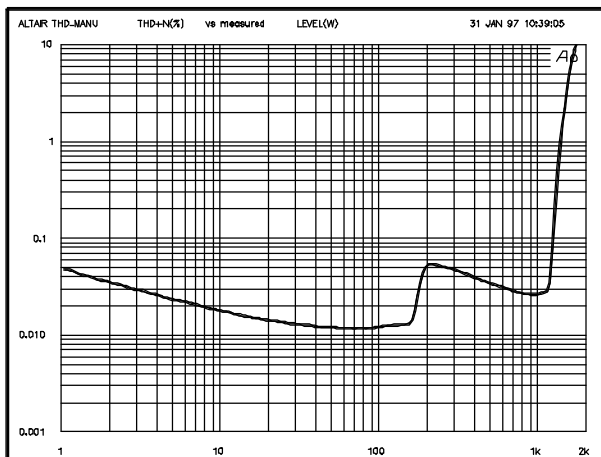

MF24: Total harmonic distortion versus output power, into 4 Ω, at 1 KHz.

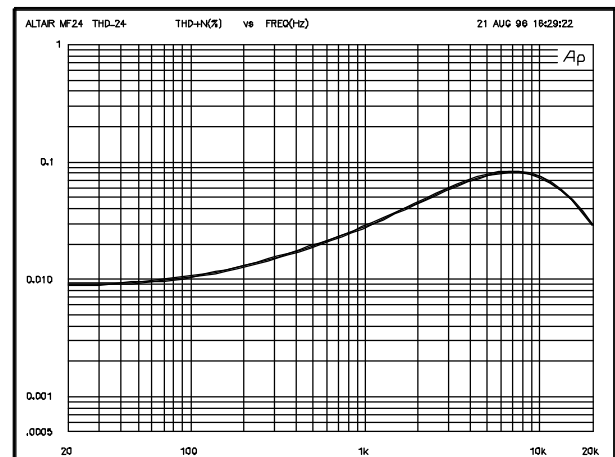

MF24: Total harmonic distortion versus frequency at rated output power, into 4Ω.

## 10. WARRANTY

This unit is warranted by Equipos Europeos Electrónicos to the original user against flaws in the manufacturing and in the materials for a length of time of one year, starting from the date of sale.

Flaws due to misuse of the unit, internal modifications or accidents are not covered by this warranty.

There is no other warranty expressed or implicit.

Any faulty unit must be sent, to the dealer or the manufacturer. The serial number of the unit must be included with any request for the service.

Equipos Europeos Electrónicos reserves the right to modify the prices or the technical specifications without notice.

**SERIAL NUMBER .....**

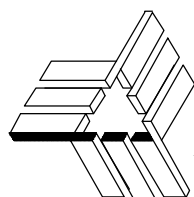
**ALTAiR****EQUIPOS EUROPEOS ELECTRÓNICOS, S.A.L.**

Avda. de la Industria, 50. 28760 TRES CANTOS-MADRID (ESPAÑA).



91-804 32 65



91-804 43 58



altair@altairaudio.com.

[www.altairaudio.com](http://www.altairaudio.com)

# European Union Waste Electronics Information Unión Europea Información sobre residuos electrónicos

## **Waste from Electrical and Electronic Equipment (WEEE) directive**

The WEEE logo signifies specific recycling programs and procedures for electronic products in countries of the European Union. We encourage the recycling of our products. If you have further questions about recycling, contact your local sales office.

## **Directiva sobre Residuos de Aparatos Eléctricos y Electrónicos (RAEE)**

El logotipo de la Directiva RAEE se refiere a los programas y procedimientos específicos de reciclaje para aparatos electrónicos de países de la Unión Europea. Recomendamos el reciclaje de nuestros productos. Si tiene alguna consulta, póngase en contacto con su Distribuidor.

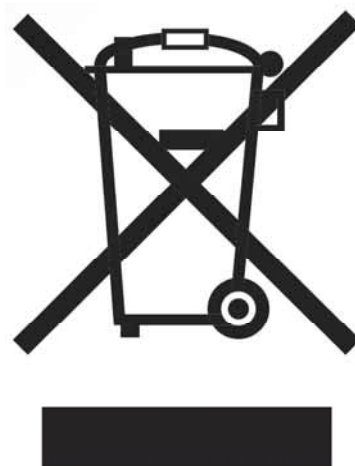

Information based on European Union WEEE Directive 2002/96/EC

Información basada en la Directiva de la unión europea RAEE 2002/96/EC y el Real Decreto 208/2005

**AUDIO ELECTRONICS DESIGN**



**EQUIPOS EUROPEOS ELECTRÓNICOS, S.A.L**

Avda. de la Industria, 50. 28760 TRES CANTOS-MADRID (SPAIN).



34-91-761 65 80



34-91-804 43 58



[altair@altairaudio.com](mailto:altair@altairaudio.com)

[www.altairaudio.com](http://www.altairaudio.com)